

Weld Creation Guide for exporting to CortexPrime

General Guidelines

There is two ways to model welds, standard triangle weld or simpler cylindrical weld.
Also, it is important that in the exported .step file, all the welds body must be named the same way. For example, "WELD".

Triangle Welds

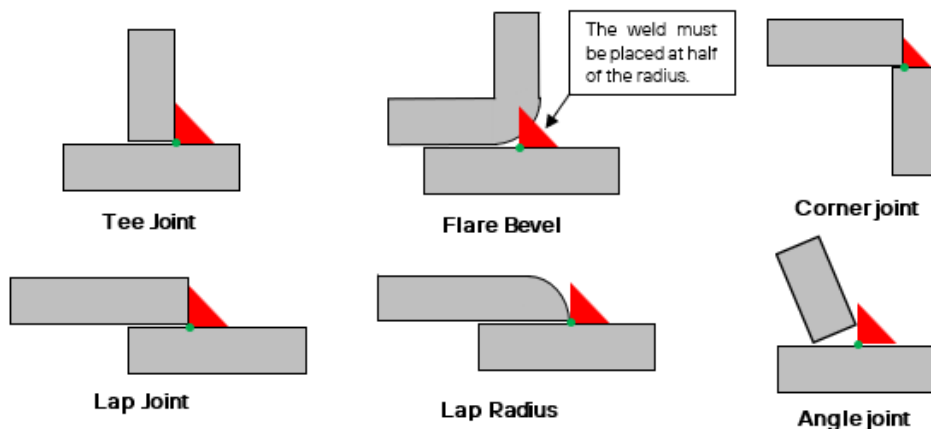

With triangular weld, the weld should always be a right angled triangular prism. Also, the weld leg size is always equal to the samll edge of the triangle (not the hypotenuse).

Example

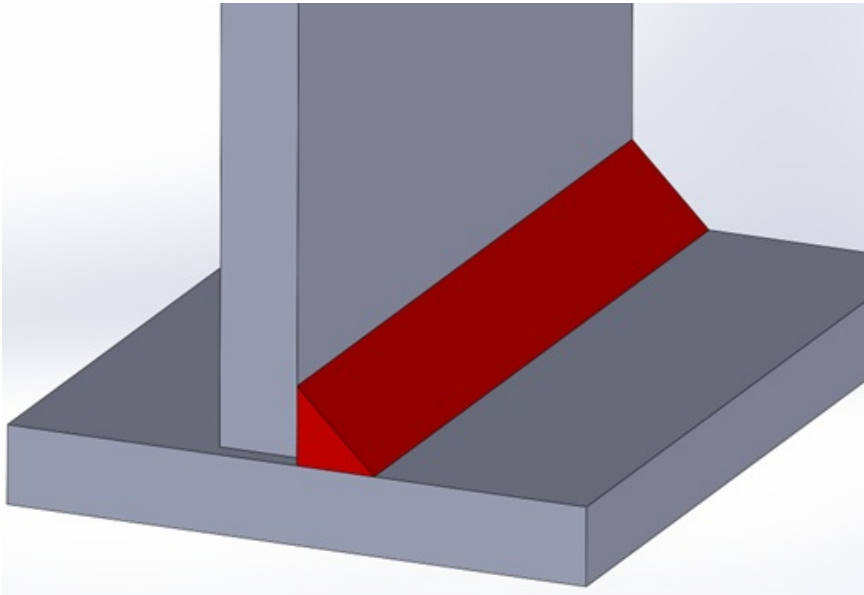

Cylindrical Welds

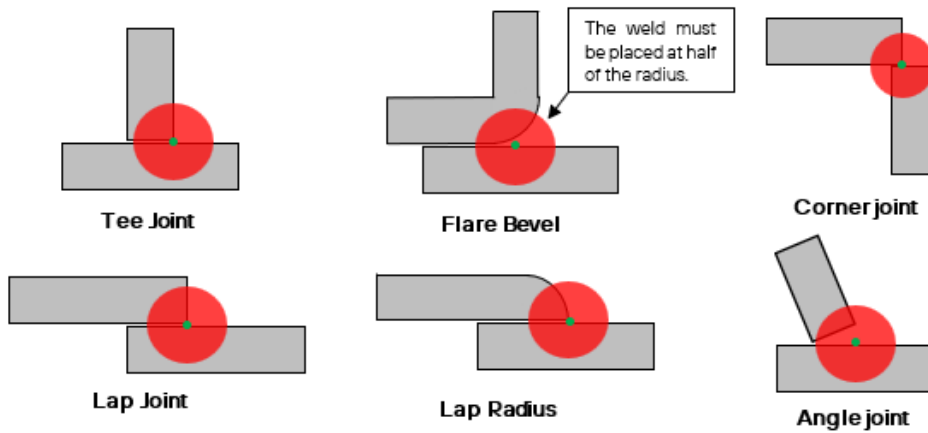

With cylindrical weld, the weld should always be a cylinder. Also, the radius of the cylinder is equal to the weld leg size.

Example:

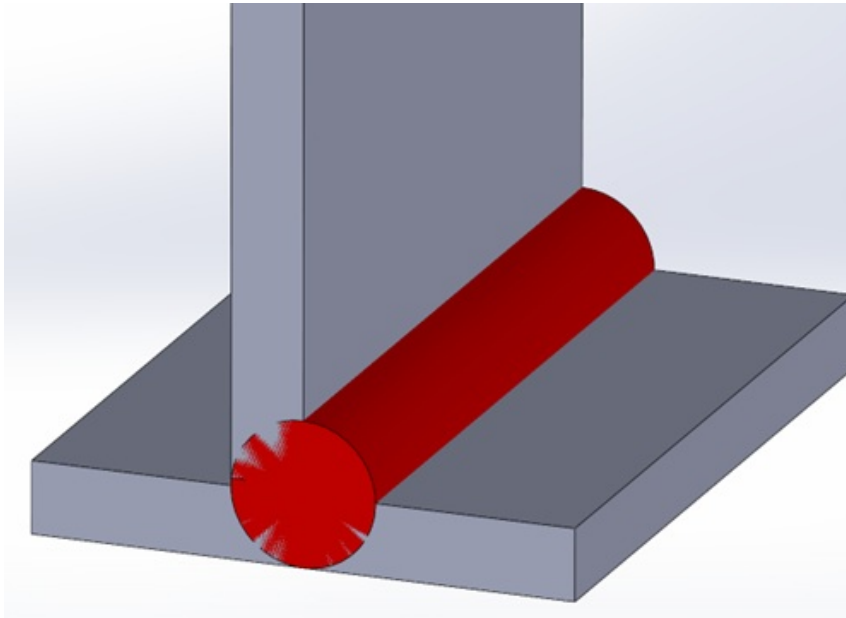

.CSV file welds

Here is exactly where the segment should be placed for each weld type (identified by the green dots).

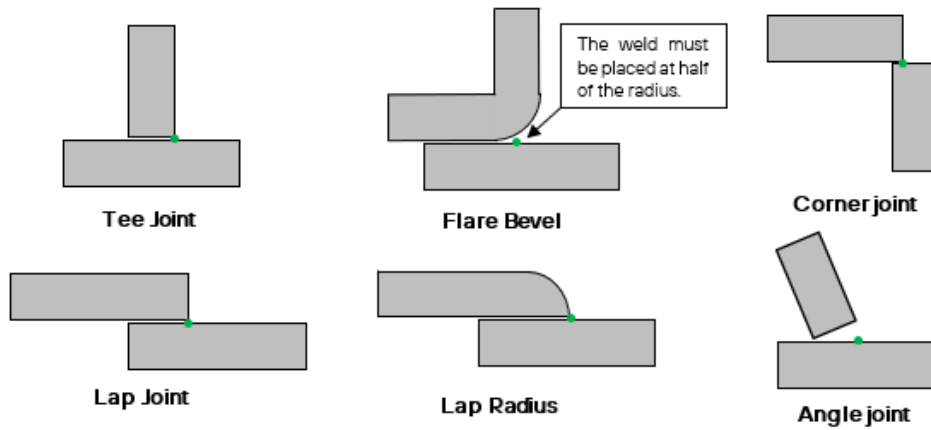

For imperial system, use this model as an example...



AGT ROBOTICS

8800 boul. Parent

Trois-Rivières QC G9A5E1

Canada

	A	B	C	D	E	F	G	H	I
1	WeldId	WeldType	WeldSize	StartX	StartY	StartZ	StopX	StopY	StopZ
2	1	FILLET	003	7.46875	11.59502	0.75	7.46875	13.59502	0.75
3	2	FILLET	003	7.46875	19.59503	0.75	7.46875	21.59503	0.75
4	3	FILLET	003	7.46875	27.59503	0.75	7.46875	29.59503	0.75
5	4	FILLET	003	7.375	41.85475	3.95721	7.375	36.46032	3.95721
6	5	FILLET	003	7.46875	45.22004	0.75	7.46875	47.22004	0.75
7	6	FILLET	003	7.46875	53.22004	0.75	7.46875	55.22005	0.75
8	7	FILLET	003	7.46875	59.84505	4	7.46875	57.34505	4
9	8	FILLET	003	7.46875	62.59505	0	7.46875	64.59505	0
10	9	FILLET	003	7.46875	70.59505	0	7.46875	72.59505	0
11	10	FILLET	003	7.46875	78.59506	0	7.46875	80.59506	0
12	11	FILLET	003	7.46875	84.8041	3.77366	7.46875	88.38602	3.77366
13	12	FILLET	003	7.46875	93.09507	0	7.46875	95.09507	0
14	13	FILLET	003	7.46875	99.80411	3.77366	7.46875	103.386	3.77366
15	14	FILLET	003	7.46875	108.0951	0	7.46875	110.0951	0
16	15	FILLET	003	7.46875	114.8041	3.77366	7.46875	118.386	3.77366

For metric system, use this model as an example...

	A	B	C	D	E	F	G	H	I
1	WeldId	WeldType	WeldSize	StartX	StartY	StartZ	StopX	StopY	StopZ
2	1	FILLET	4.8	189.71	294.51	19.05	189.71	345.31	19.05
3	2	FILLET	4.8	189.71	497.71	19.05	189.71	548.51	19.05
4	3	FILLET	4.8	189.71	700.91	19.05	189.71	751.71	19.05
5	4	FILLET	4.8	187.32	1063.11	100.51	187.32	926.09	100.51
6	5	FILLET	4.8	189.71	1148.59	19.05	189.71	1199.39	19.05
7	6	FILLET	4.8	189.71	1351.79	19.05	189.71	1402.59	19.05
8	7	FILLET	4.8	189.71	1520.06	101.6	189.71	1456.56	101.6
9	8	FILLET	4.8	189.71	1589.91	0	189.71	1640.71	0
10	9	FILLET	4.8	189.71	1793.11	0	189.71	1843.91	0
11	10	FILLET	4.8	189.71	1996.31	0	189.71	2047.11	0
12	11	FILLET	4.8	189.71	2154.02	95.85	189.71	2245	95.85
13	12	FILLET	4.8	189.71	2364.61	0	189.71	2415.41	0
14	13	FILLET	4.8	189.71	2535.02	95.85	189.71	2626.01	95.85
15	14	FILLET	4.8	189.71	2745.61	0	189.71	2796.41	0
16	15	FILLET	4.8	189.71	2916.02	95.85	189.71	2907.01	95.85

AGT Robotics Inc.

8800 boul. Parent, Trois-Rivières, QC, Canada, G9A 5E1

Tel: (819) 693-9682 | Mail: agtssupport@agt-group.com | Web: http://www.agtrobotics.com

In column B (WeldType), "FILLET" can always be used for any joint type.

Also, in the column D (WeldSize), represent the represent the weld leg size in millimetre.

Finally, the column from D to I represent the positions (mm) of the start and end points of each weld in relation to the origin of the exported part.